

Gravity Shake Freezer

Model 77WS

The externally mounted mixer blends flavor into the shake product as it is dispensed from the spigot. The fast, easy way to serve flavors regardless of the viscosity of the flavoring syrup or the fruit pulp it contains. You may also order the freezer with a plunger head in place of the spindle dispensing head for serving single flavor shakes.

Special Features

Dispensing Head

The finest in insulating materials. . .no frost or sweating. Easy pull-down handle, adjustable for dispensing speed.

Beater Blades

Plastic, durable & long wearing.

20 Quart Mix Hopper

Insulated for minimum cold loss with separate refrigeration controls.

Refrigeration

404a Refrigerant. . .permits fast freeze down, quick recovery and high volume capacity.

Mix Feed

Specially designed to maintain optimum overrun.

Mix Level Indicator

Flashing light automatically tells operator when mix is needed.

Construction

Sturdy angle iron frame, stainless steel mix hopper, beater and freezing cylinder.

Paneling

Top, front and sides are stainless steel.



Model 77WS

ELECTRO FREEZE®

Plumbing & Electrical Connections

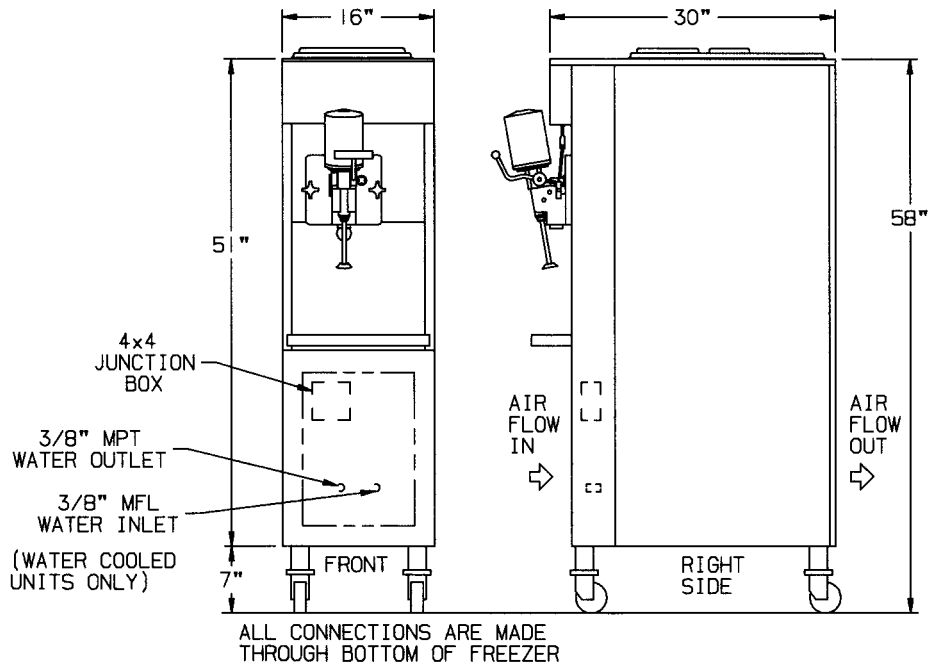

Model 77WS

SPECIFICATIONS

All specifications subject to change without notice.

MODEL NO.	MOTOR H.P.		DIMENSIONS			NET WT.	TOTAL AMPS			
	Beater	Compressor	D.	W.	H.		1 Phase Water	1 Phase Air	3 Phase Water	3 Phase Air
77WS	1 HP	1.5 HP 10,000 BTU	30" 76 CM	16" 41 CM	58" 147 CM	520 LB. 236 KG.	19.6	21.0	10.1	11.5
							MINIMUM CIRCUIT AMPACITY			
							22.5	24.0	11.5	13.0

Self contained air or water cooled.

REFRIGERANT: R404a

MIX HOPPER CAPACITY: 20 Quarts

WIRING - 230 volts, A.C., 60 cycle, Single Phase - 3 wire
208-230 volts, A.C., 60 cycle, Three Phase - 4 wire

Note: Units equipped with a spindle mixer require a neutral wire to complete the 115 volt spindle motor circuit.

Electrical characteristics other than above available on request.

Authorized Distributor

division of H.C. DUKE & SON, INC.

2116 - 8th Avenue • East Moline, Illinois 61244

Phone (309) 755-4553 • (800)755-4545

Fax (309) 755-9858

E-mail: sales@electrofreeze.com • www.electrofreeze.com

Certified and/or listed by:



*Listed by Underwriters Laboratories under Canadian National Standard C22.2 No. 120-M91