



MODEL 15-77 RMT



MODEL 15-10 CMT

FREEDOM 360° SERIES

SHAKE/SOFTSERVE PRESSURIZED MODELS WITH MIX TRANSFER SYSTEM

MODEL 15-77RMT

...a combination unit. Two complete and separate pressurized machines in one refrigerated cabinet. The 15 side is a high volume capacity, pressurized soft serve unit with the same components, dispensing capacity, etc. of the model 15RMT. The 77 pressurized shake freezer side has a spindle head for mixing and dispensing a flavored shake in one operation. A plunger head is optional if you wish to dispense only one flavor. Has the same dispensing capacity and components as the 77RMT.

MODEL 15-10CMT

...A combination unit. Two complete and separate pressurized freezers in one cabinet. The Model 15 side is a high volume soft serve unit with the same components, dispensing capacity, etc. of the Model 15N-CMT-W. The 10 side is the complete unit of the 4 flavor direct draw Model 10CMT.

REFRIGERATED MIX CABINET

...Located in the lower portion of the Freezer-provides easy access for filling mix reservoirs. Place the mix carton into the cabinet or fill containers, insert the mix tube from each mix transfer system and you are ready to make product— automatically.

NIGHT SWITCHES

...permit you to close shop at the end of a business day and all mix in the Freezer (cabinet and cylinders) will remain under refrigeration, ready for operation the next day.

CYCOLAC DISPENSING HEADS

...the finest insulating material...no frost – no drip. Easy pull down handle, adjustable dispensing speed.

MIX TRANSFER SYSTEM*

...The revolutionary mix transfer system has only 9 parts to disassemble for cleaning. It's so simple it takes only minutes...all the benefits of a pressurized system with the cleaning time of a gravity fed freezer.

BEATER BLADES

...Plastic, durable and long wearing...eliminates heat producing metal-to-metal contact.

MIX LEVEL INDICATOR

...Flashing light automatically tells operator when mix is needed.

* U.S. Patent #5,349,825

BATCH
FROZEN COCKTAIL
SLUSH
SHAKE
YOGURT
SOFT SERVE

ELECTRO FREEZE®

PLUMBING AND ELECTRICAL CONNECTIONS

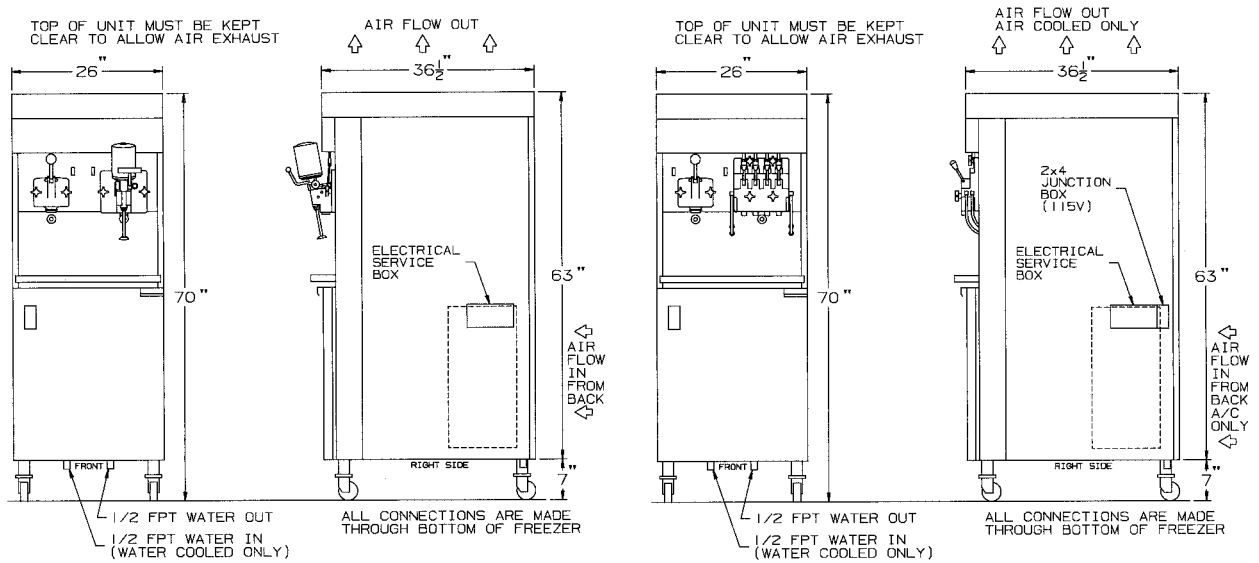

MODEL 15-77RMT

MODEL 15-10CMT

SPECIFICATIONS

All specifications subject to change without notice. Check name plate for exact electrical data.

MODEL NO.	MOTOR		DIMENSIONS			NET WT.	TOTAL AMPS			
	Beater	Compressor	D.	W.	H.		1 Phase Water	1 Phase Air	3 Phase Water	3 Phase Air
15-10CMT	2 HP	9,500 BTU (15)	36 1/2"	26"	66 1/2"	907 LB 411 KG	44.5	48.9	27.3	31.7
	1.5 HP	12,000 BTU (10)	93 cm	66 cm	171 cm					
15-77RMT	2 HP	9,500 BTU (15)	36 1/2"	26"	66 1/2"	1035 LB 469 KG	43.0	47.4	25.1	29.5
	1 HP	9,200 BTU (77)	93 cm	66 cm	171 cm					
MODEL							MINIMUM CIRCUIT AMPACITY			
15-10CMT							(1) 27.0	(1) 28.5	(1) 16.0	(1) 18.0
							(1) 26.0	(1) 28.0	(1) 15.5	(1) 17.5
15-77RMT							(1) 27.0	(1) 28.5	(1) 16.0	(1) 18.0
							(1) 23.5	(1) 25.5	(1) 12.5	(1) 14.5

Water or Air cooled self contained.

15-10CMT Standard wiring—230 volts A.C., 60 HZ, Single Phase—2 wire
208 or 230 volts A.C., 60 HZ, Three Phase—3 wire

15-77RMT Standard wiring—230 volts A.C., 60 HZ Single Phase—3 wire—Neutral Required
208 or 230 volts A.C., 60HZ, Three Phase—4 wire—Neutral Required

Electrical characteristics other than above available on request from Sales Office.

AUTHORIZED DISTRIBUTOR

MIX CABINET DIMENSIONS		
D.	W.	H.
17"	22"	26"
43 CM	56 CM	66 CM

division of **H.C. DUKE & SON, INC.**

2116-8th AVENUE, EAST MOLINE, ILLINOIS 61244 •
Phone (309) 755-4553 • FAX (309) 755-9858

Certified and/or listed by:

